

Approximate dimensions for drive contactors

Type EHDB 2 & 3 pole

EHDB130 – EHDB960

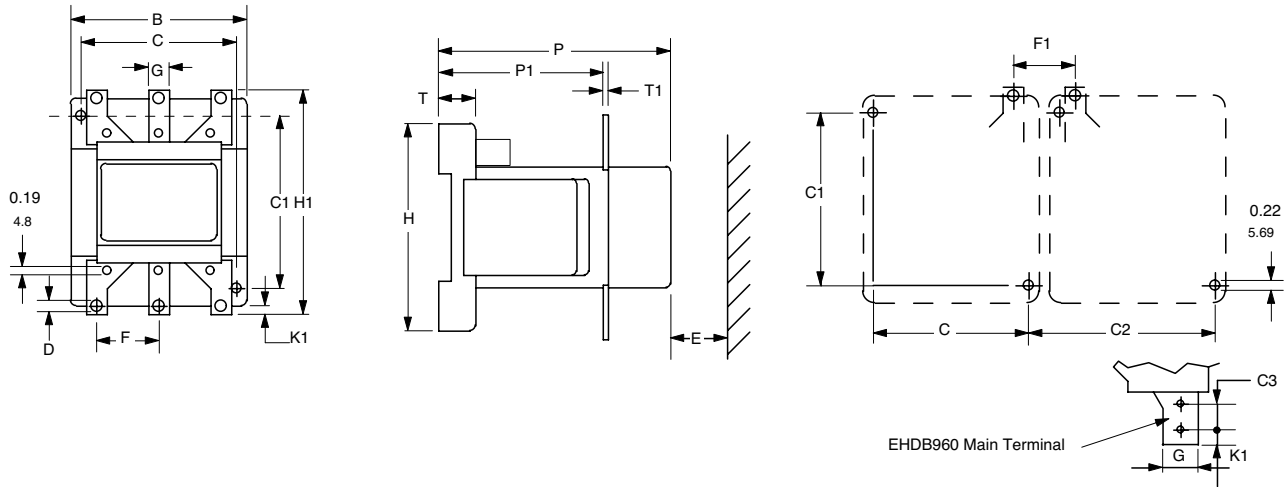

DIM.	B			B2	C	C1	C2				E	D	F	G	H	H1	K1	P	P1	T	T1	C3
	1, 2	3	4				①	≠	③	√												
	Aux. contact block																					
EHDB130in	4.88	5.31	5.75	5.94	4.33	4.72	5.00	5.00	5.35	5.79	1.57	0.43	1.61	0.79	5.51	6.73	0.39	5.63	3.58	0.75	0.16	—
	124	135	146	151	110	120	127	127	136	147	40	11	41	20	140	171	10	143	91	19	4	—
EHDB220in	5.35	5.83	6.30	6.46	4.72	5.51	5.39	5.39	5.87	6.34	0.59	0.24	1.77	0.79	6.14	7.79	0.39	6.65	4.06	0.41	0.20	—
	136	148	160	164	120	140	137	137	149	161	15	6	45	20	156	198	10	169	103	10.5	5	—
EHDB280in	5.35	5.83	6.30	6.46	4.72	5.51	5.39	5.39	5.87	6.34	0.59	0.24	1.77	0.79	6.14	7.79	0.39	6.65	4.06	0.41	0.20	—
	136	148	160	164	120	140	137	137	149	161	15	6	45	20	156	198	10	169	103	10.5	5	—
EHDB360in	6.92	7.44	7.72	8.11	6.30	5.51	7.20	7.32	7.48	7.76	1.18	0.24	2.44	0.98	6.14	8.14	0.49	6.88	4.21	0.7 ^⑤	0.20	—
	176	189	196	206	160	140	183	186	190	197	30	6	62	25	156	207	12.5	175	107	19	5	—
EHDB520in	7.80	8.23	8.62	8.90	6.69	7.87	7.91	7.91	8.19	8.54	1.57	0.24	2.64	0.98	8.78	10.71	0.49	8.90	5.51	0.9 ^⑤	0.24	—
	198	209	219	226	170	200	201	201	208	217	40	6	67	25	223	272	12.5	226	140	23 ^⑤	6	—
EHDB650in	7.80	8.23	8.62	8.90	6.69	7.87	7.91	7.91	8.19	8.54	1.57	0.24	2.64	0.98	8.78	10.71	0.49	8.90	5.51	0.9 ^⑤	0.24	—
	198	209	219	226	170	200	201	201	208	217	40	6	67	25	223	272	12.5	226	140	23 ^⑤	6	—
EHDB800in	9.61	9.96	10.31	10.63	8.66	7.87	9.69	9.69	10.00	10.35	1.57	0.24	3.23	1.57	8.78	11.57	0.79	8.90	5.51	0.9 ^⑤	0.24	—
	244	253	262	270	220	200	246	246	254	263	40	6	82	40	223	294	20	226	140	23 ^⑤	6	—
EHDB960in	9.61	9.96	10.31	10.63	8.66	7.87	9.69	9.69	10.00	10.35	1.57	0.24	3.23	1.57	8.78	11.57	0.79	8.90	5.51	0.9 ^⑤	0.24	1.36
	244	253	262	270	220	200	246	246	254	263	40	6	82	40	223	294	20	226	140	23 ^⑤	6	34.5

① Minimum dimension

≠ Makes distance F1 = F

③ Includes space for three auxiliary contact blocks between the contactors.

√ Includes space for four auxiliary contact blocks between the contactors.

⑤ Damping elements are included.

NOTE: Screw, nut and washer are included for terminal hardware.

Drive contactors

Mounting positions, Type BHD & EHDB

Type BHD & EHDB

